



IOECN MACHINE

Jinan Penn CNC Machine Co.,Ltd.
Add:No.154 Huayuan Road,Jinan,Shandong,China
Tel:0086-531-69956820 Fax:0086-531-69956821
Web:www.fastcnc.com
Email:info@fastcnc.com

N95,FFP2/3 model face mask automatic making machine

-for high quality and high rate of finished mask
35pcs/min

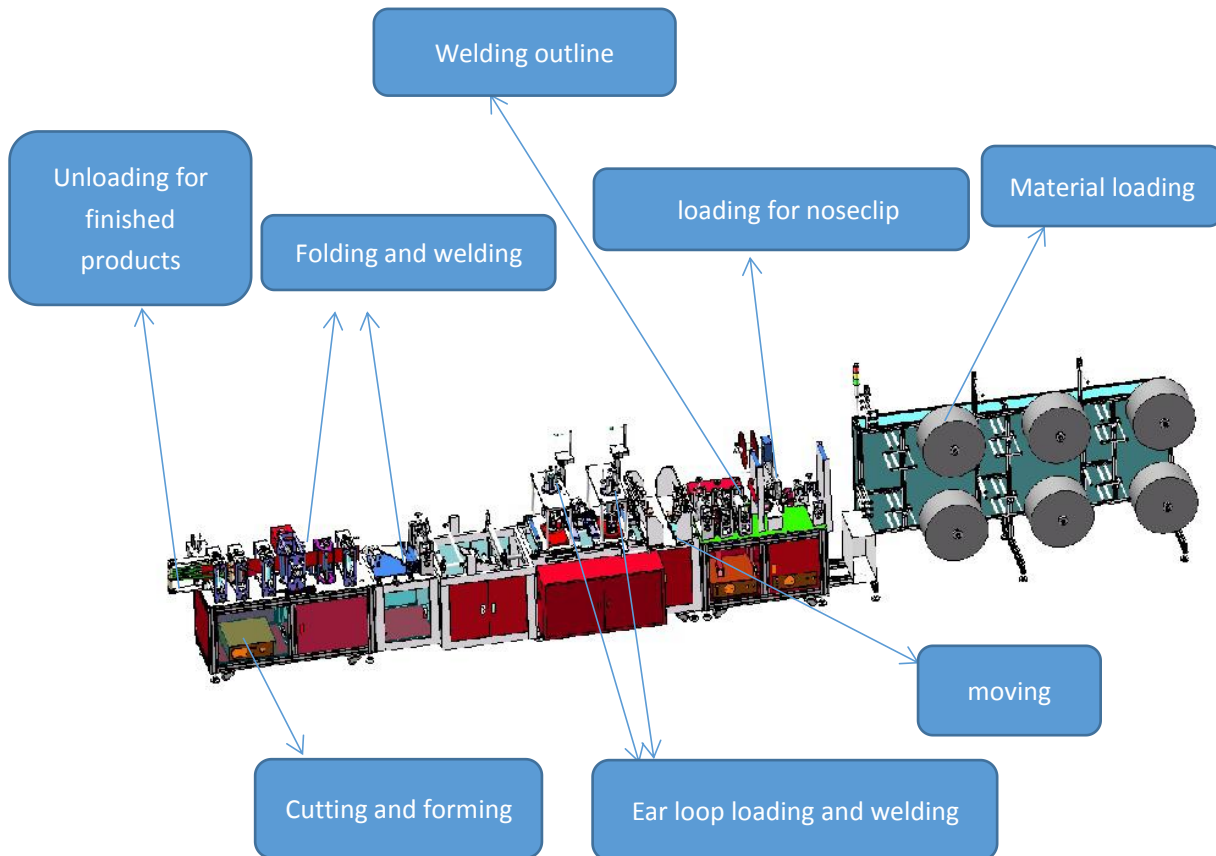



IOCCN MACHINE

Jinan Penn CNC Machine Co.,Ltd.
Add:No.154 Huayuan Road,Jinan,Shandong,China
Tel:0086-531-69956820 Fax:0086-531-69956821
Web:www.fastcnc.com
Email:info@fastcnc.com

Mask making procedure:

Materials loading(available for 3-6 layers materials)

Noseclip loading

Welding outline

Printing pictures or letters

Welding ear loop

Folding and welding face mask

Cutting and forming



IOCEN MACHINE

Jinan Penn CNC Machine Co.,Ltd.
Add:No.154 Huayuan Road,Jinan,Shandong,China
Tel:0086-531-69956820 Fax:0086-531-69956821
Web:www.fastcnc.com
Email:info@fastcnc.com

Machine Feature:

1. Machine weight:≤6000kg, Ground load-bearing:≤500KG/m²
2. Working voltage: AC380V,50HZ, rated power rate:16KW
3. Compressed air: 0.5~0.7 MPa, rate of flue:300L/min
4. Required environment: 10~35°C,5-35%HR, no combustibility or corrosiveness gas, no dust(air cleanlinessclass at least ISO class 8)
5. Producing ability: 35pcs/min

Machine Parts:

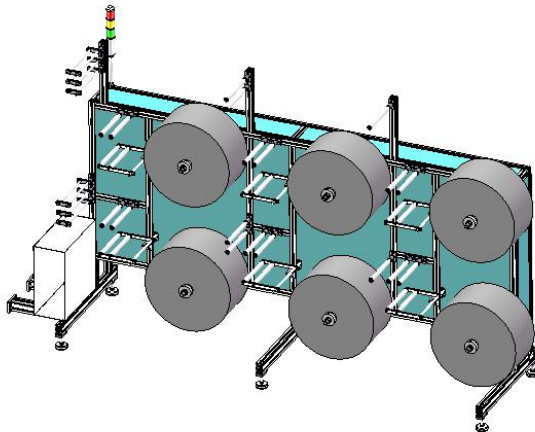



IOCCN MACHINE

Jinan Penn CNC Machine Co.,Ltd.
Add:No.154 Huayuan Road,Jinan,Shandong,China
Tel:0086-531-69956820 Fax:0086-531-69956821
Web:www.fastcnc.com
Email:info@fastcnc.com

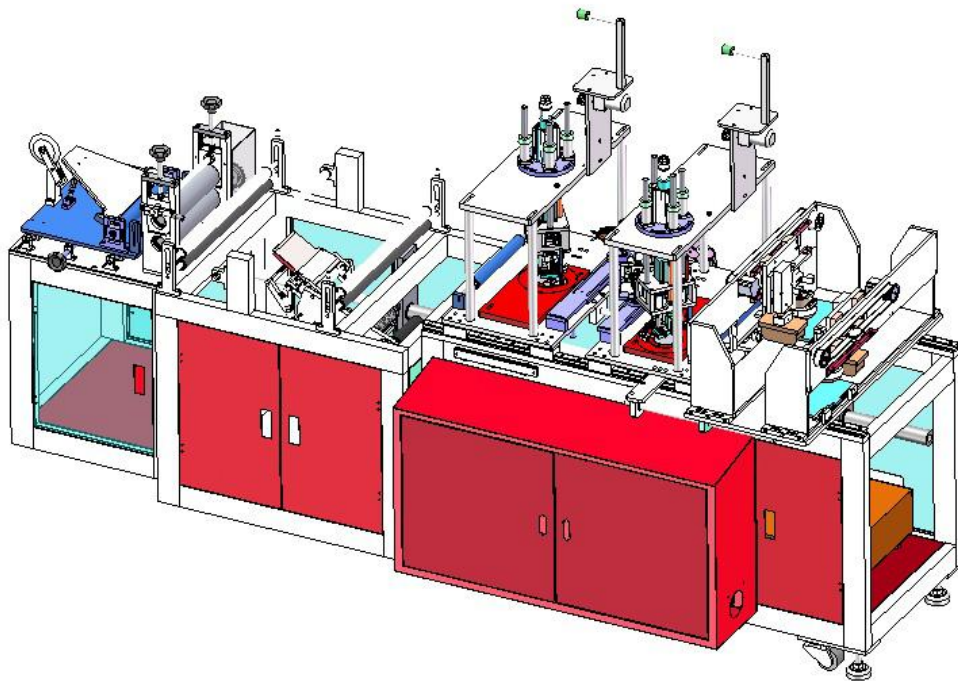
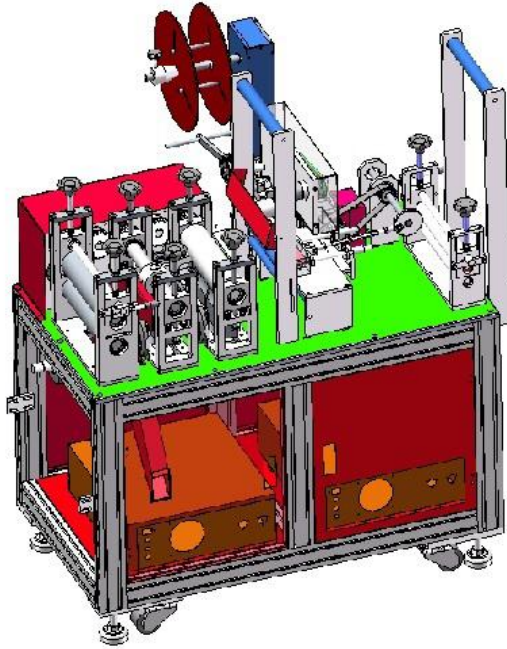



IOECN MACHINE

Jinan Penn CNC Machine Co.,Ltd.
Add:No.154 Huayuan Road,Jinan,Shandong,China
Tel:0086-531-69956820 Fax:0086-531-69956821
Web:www.fastcnc.com
Email:info@fastcnc.com

